

R3162D Blade PC Quick Start Guide

R3162D Blade PC Overview

Front panel

The picture and table below show the R3162D front panel and describe each front panel feature.

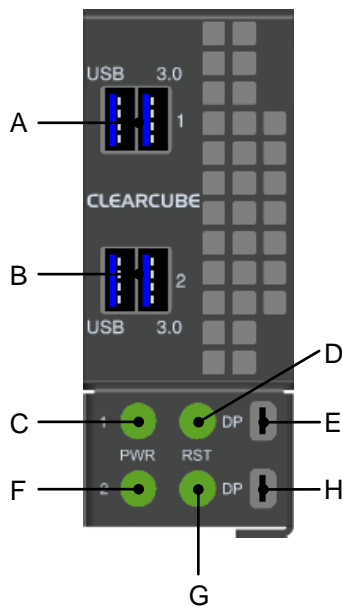

Letter	Part	Function
A	Computer #1 USB 3.0 ports	USB connectors (× 2) for computer #1 in the R3162D Blade PC.
B	Computer #2 USB 3.0 ports	USB connectors (× 2) for computer #2 in the R3162D Blade PC.
C	Computer #1 Power button and indicator	<p>Button: Press to power on and off blade. Press and hold for three seconds to force power off. Button is illuminated (solid) when power is on.</p> <p>Indicator light: Flashes slowly when blade is in standby (Windows Sleep power state).</p>
D	Computer #1 Reset button and indicator	<p>Button: Press to reset blade power.</p> <p>Indicator light: Flashes to indicate storage drive activity.</p>
E	Computer #1 DisplayPort connector	Local DisplayPort connector for computer #1.
F	Computer #2 Power button and indicator	Power and standby indicator for computer #2. See Function description for item C above.
G	Computer #2 Reset button and indicator	Power reset and hard drive indicator for computer #2. See Function description for item D above.
H	Computer #2 DisplayPort connector	Local DisplayPort connector for computer #2.

Continued on next page

R3162D Blade PC Overview, Continued

Two computers in one blade

The R3162D Blade PC is one blade containing two motherboards. The blade's front panel provides power controls and input and output connectors for both computers, and the R4300 chassis provides separate network connections for each computer. This arrangement enables you to double the user density in your existing rack space and enables remote management of both of the computers in a single rack slot. The picture below shows an R3162D blade.

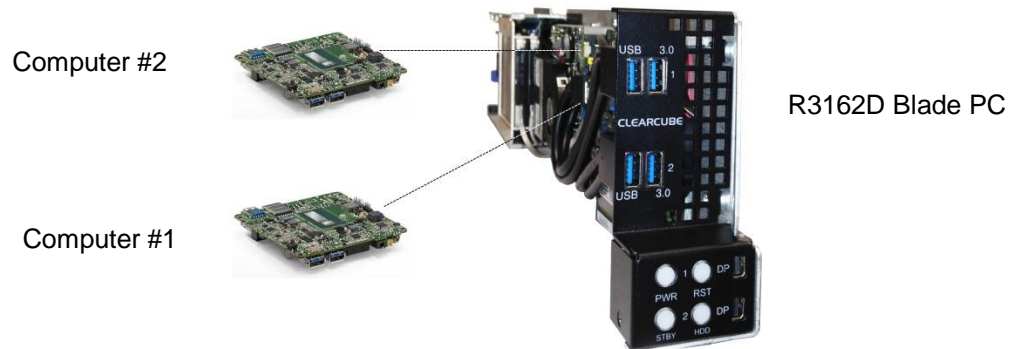

Figure 1. The R3162D Blade PC contains two computers

Overview of blade architecture

R3162D Blade PCs are 3U-high, single-slot blades that mount in an R4300 Chassis. Eight R3162D blades can fit in one R4300 Chassis, which provides power, network interfaces, and USB ports for each blade. This dense configuration enables one R4300 Chassis populated with eight R3162D blades to provide 16 computers in 3 rack units.

In typical ClearCube environments, blades are centrally-located in data centers. Each blade user has a zero client or thin client on their desk that is connected over an IP network to an R3162D blade. Zero or thin clients provide the interface to the blade (that is, monitors, keyboard, mouse, and so on).

The picture below shows a high-level example of zero clients and thin clients connected to R3162D blades in an R4300 chassis.

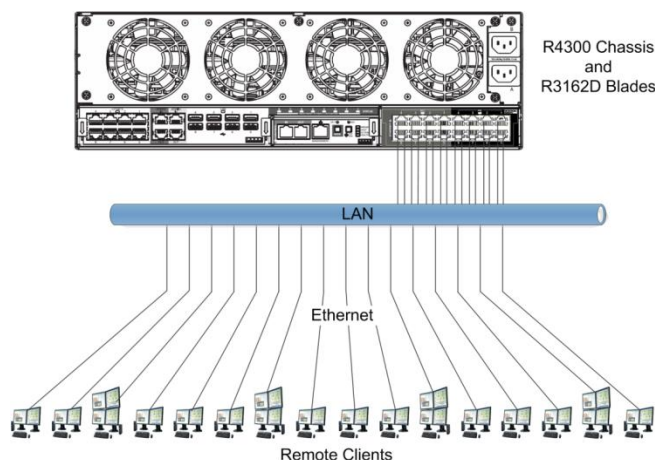

Figure 2. R4300 Chassis with eight R3162D blades connected to 16 clients over an IP network

Continued on next page

R3162D Blade PC Overview, Continued

Connection types

R3162D blades supports client connections using Remote Desktop connections (RDP) and from PCoIP® clients (physical or software-based).

R3162D and the Blade Chassis

Inserting a blade in a chassis

The R4300 chassis (shown in [Figure 2](#) above) provides blade power, network ports, and USB ports for all blades in a chassis.

The steps below show how to insert an R3162D blade in an R4300 chassis.

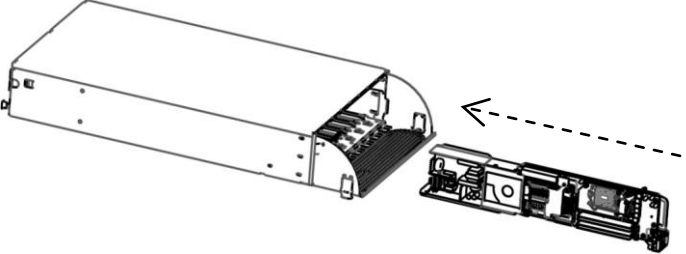
Step	Action
1	Lower the front bezel on the chassis by depressing the latches on each side of the bezel.
2	Orient each blade right-side up (so the front panel buttons are on the bottom). Slowly insert the blade into the chassis by lining up the blade edges with the top and the bottom slot guides.
3	<p>Start inserting blades from the left-most slot (slot #1). There is a slight resistance when the back connector goes into the backplane socket.</p>  <p>Figure 3. Inserting a blade in an R4300 chassis</p> <p>When properly seated, the Blade PC is flush with the front edge of the bottom guide bracket.</p> <div style="border: 1px solid black; padding: 5px; background-color: #f0f0f0;"> <p>CAUTION: Never force blades into a chassis. Mishandling blades can cause critical hardware failure, data loss, or both.</p> </div>
4	After inserting all blades, raise the chassis front bezel and snap into place.

Continued on next page

R3162D and the Blade Chassis, Continued

Removing a blade from a chassis

The steps below show how to remove an R3162D from a chassis.

Step	Action
1	<p>Open the chassis door and press the power buttons, located on the left-hand side of the front panel, for both R3162D computers. (See “Front panel” above for the location of the power buttons.) Wait for the power lights to turn off.</p> <div style="border: 1px solid black; padding: 5px; background-color: #f0f0f0;"> <p>CAUTION: Always completely power down a blade using the power button or by shutting down the OS before removing it from a chassis. Removing a blade before completely powering down both computers can cause critical hardware failure, data loss, or both.</p> </div>
2	<p>Hold the blade by the handle and pull back to remove the blade. Support the rear of the blade as you remove it from the chassis.</p> <div style="border: 1px solid black; padding: 5px; background-color: #f0f0f0;"> <p>CAUTION: Never forcefully remove blades from a chassis. Mishandling blades can cause critical hardware failure, data loss, or both.</p> </div> <div style="border: 1px solid black; padding: 5px; background-color: #f0f0f0; margin-top: 10px;"> <p>CAUTION: Use care when handling blades; some surface might be hot.</p> </div>

Network cabling

The R4300 Chassis provides eight blade slots. The *Network Module* on the rear of an R4300 Chassis provides two Gigabit Ethernet ports (one Primary port and one Secondary port) for each blade.

- **Primary ports (Pri)**—support computer #1 in the R3162D blade. Primary ports are located on the right-most side of the Network Module.
- **Secondary ports (Sec)**—support computer #2 in the R3162D blade. Secondary ports are located on the left-most side of the Network Module.

The Network Module port numbers correspond to R4300 chassis slots. Slot 1 is the left-most slot, and slot 8 is the right-most slot as you face the front of the chassis.

The picture below shows the Network Module on the rear of the R4300 Chassis.

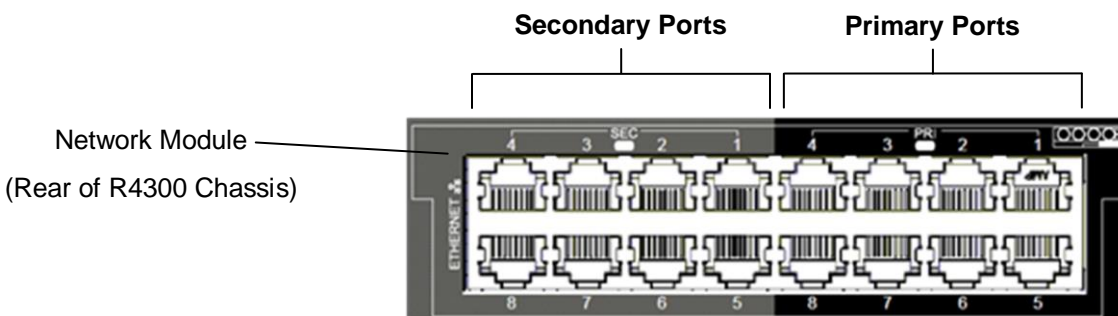

Figure 4. Primary ports support computer #1 and secondary ports support computer #2 in an R3162D

Local Blade Access at Chassis

About local use at chassis

You can connect a monitor, keyboard, and mouse to the I/O ports on the R3162D front panel a blade locally. You might need to access a blade to view pre-OS video (POST codes and BIOS setup utility screens) or to configure a blade from the operating system.

Before you begin

Before you begin, be sure to have

- a USB keyboard, and
- a monitor, power cable, and video cable with a mini-DisplayPort connector

Connecting devices

The steps below show how to connect devices to view pre-OS video (see *R4300 Chassis Quick Start Guide*, available on the Support site, for more information about the R-Series chassis).

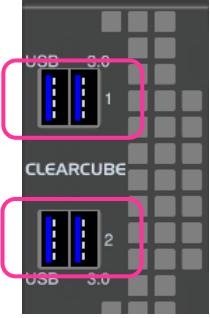
Step	Action
1	Insert a blade in the chassis as described in “ Inserting a blade in a chassis ” above.
2	<p>The R3162D blade contains two computers (shown as 1 and 2 on the front of the blade). Connect a USB keyboard to a USB port on the front of the blade for the computer you are configuring. Optionally, connect a USB mouse.</p> <div style="text-align: center;">  <p>Computer #1 USB Ports</p> <p>Computer #2 USB Ports</p> </div> <p>Figure 5. USB ports for computer #1 and computer #2</p>

Continued on next page

Local Blade Access at Chassis, Continued

Connecting devices (continued)

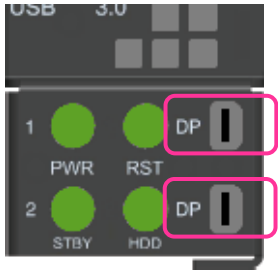
Step	Action
3	<p>Connect a monitor to the appropriate Mini DisplayPort connector (MiniDP) on the front of the blade.</p>  <p style="text-align: right;">Computer #1 MiniDP Computer #2 MiniDP</p> <p style="text-align: center;">Figure 6. mini-DisplayPorts for computer #1 and computer #2</p>
4	<p>Connect the monitor power adapter to the monitor and then plug the cord into a power outlet. Power on the monitor.</p>

Next steps: power on devices, and view pre-OS video.

Power on blade and view video

The steps below show how to view pre-OS video.

Step	Action
1	<p>As noted above, the R3162D blade contains two computers. Press the power button on the front of the blade for the computer you are configuring (see step 2 above for the location of buttons for each computer).</p>
2	<p>To access the R3162D BIOS:</p> <ol style="list-style-type: none"> a) When prompted, press the F2 key to enter the BIOS Setup utility. b) After performing configuration steps, press F10 to save changes and reset the blade.
3	<p>If an operating system is installed, you can boot to the operating system.</p>

Preparing Blades for Remote Connection

Supported protocols and devices

Supported remote protocols:

- Microsoft RDP
- Teradici Cloud Access Software; Standard Edition

Supported clients:

- Thin clients (with RDP)
- Computers with Teradici PCoIP Software Client for Windows or MacOS operating system
- Android or IOS systems with Teradici PCoIP Software Client app
- Zero Clients (running Teradici firmware 4.7 or higher)

Remote connection overview

The table below provides an overview of steps required to establish a remote connection between a supported client device and a remote computer in an R3162D blade PC.

Step	Action
1	<p>Ensure all network and hardware pre-requisites are met.</p> <p>If the client connection type you are using requires permissions or configuration on the host device (blade), ensure that the blade is configured appropriately. For example, if you are using Remote Desktop connections, ensure that the necessary firewall ports are open and enable remote connections on the blade.</p>
2	<p>Optionally, record any necessary device-related information.</p> <p>Record the MAC address for each computer in the R3162D blade. MAC addresses are located on the TLA configuration label on the side of the blade. Record the MAC addresses for both computers.</p>
3	<p>Prepare network cabling on the R4300 chassis that the blade is in.</p> <p>Ensure that the blade you are connecting to has Ethernet cables connecting the blade to a network switch. (From the back of the chassis, use Ethernet cables to connect the correct Network Module ports to a network switch. Connect the Primary and Secondary ports – where the Primary port is for computer #1 in the blade and the Secondary port is for computer #2 in the blade. See “Network cabling” on page 4 for more information).</p>

Continued on next page



Preparing Blades for Remote Connection, Continued

Remote connection overview (continued)

Step	Action
4	Power on both computers. See “ Front panel ” on page 1 for the location of the power buttons for both computers in the R3162D blade.
5	Obtain host-specific details to enable connections from a remote client. Obtain additional blade-specific information, such as blade host name and IP address. The list below shows ways you can obtain host-specific details: <ul style="list-style-type: none">• Consult DHCP tables. Several moments after powering on the computers, consult appropriate DHCP tables to find the IP address for computer #1 and computer #2.• Access video locally (as shown in “Local Blade Access at Chassis” on page 5) to obtain device information.
6	Set up a client. To establish a connection with one of the computers on the host R3162D blade, ensure that the client can access the network on which the R3162D is located using the selected protocol. If the client is on a separate network, be sure there is a route from the client network to the blade network and that the appropriate network ports are open.
7	Optionally, set up access for a device management suite or connection broker such as ClearCube Sentral.

Related Information and Support

Related information

The table below shows documents about R3162D configuration, operation, and maintenance.

For information about ...	See ...
Creating custom operating system images	<i>Tech Bulletin TB00265, Operating System Image Requirements</i>
Blade and chassis setup, operation, upgrades, and maintenance	<i>R-Series Data Center Products User's Guide</i>
PCoIP device configuration and administration	<i>PCoIP System User's Guide</i>

All documentation is located at <http://www.clearcube.com/support/>

Contacting Support

Web	www.clearcube.com/support/
Email	support@clearcube.com
Toll-free	(866) 652-3400
Direct	(512) 652-3400

WEEE Disposal Guidelines

In the European Union, this electronic product falls under the European Directive (2002/96/EC) WEEE. When it reaches the end of its useful life or is no longer wanted, it should not be discarded with conventional waste, but disposed of at an approved designated recycling and/or treatment facility. Laws are different in each country, so please check with your local authorities for proper disposal instructions. For assistance, contact ClearCube at recycle@clearcube.com.

